

2/2 DIAPHRAGM OPERATED, NORMALLY CLOSED/ OPEN SOLENOID VALVE

TYPE	PRESSURE
24109	0.5 - 10 bar

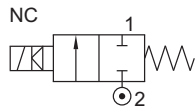

TYPE	PRESSURE
24201	0.5 - 10 bar
24202	1 - 20 bar

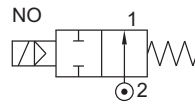

TYPE	PRESSURE
24101	0.5 - 10 bar
24102	1 - 20 bar

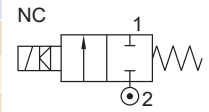

FEATURES

- Bubble tight shut off
- Manual override optionally provided
- Vibration resistance up to 9g
- Suitable for high speed cycling
- Speed up to 100 cycles/ min.
- Life >2 million cycles

WETTED PARTS

Code	※	B13	B12
Body		CF8	CF8M
Internal		SS316	SS316
Diaphragm	NBR, Viton, EPDM		
Guide Assembly	SS 304		
Shadow-Ring	Copper / Silver / None		
Plunger, Insert	SS 430		
Spring	SS 302		
Seat, Seals	NBR, Viton, EPDM		
Fasteners	SS 304		

AMBIENT AND FLUID TEMPERATURE

5 °C to 75 °C

SPECIAL VERSION AND SUFFIX

Suffix : (Valve) OX, AM
Special version : (Solenoid) CO, FR, SS, LC, III, TM

MEDIA

Air, Water, Inert Gases, Liquid, Oil, Diesel, Kerosene, LPG, CNG

APPLICATION

Drain, Deluge Valve operation, Dispensing

PORT CONNECTION

ACTION	INLET	OUTLET
NC	2	1
NO	2	1

Contact Rotex for

- Any other ambient, fluid temperature, media and application
- UL listed, (UL) Listed general purpose Valve



OIL Media Temperature Restricted from 0 °C to 100 °C

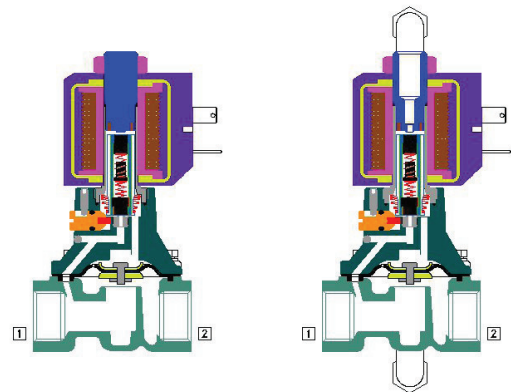

SPARES

(Refer page 25 for ordering code)

SPARE KIT	CODE
Diaphragm Kit : Diaphragm Kit	100
Seal Kit : Oring Set, Diaphragm Kit, Plunger Assembly	98
Repair Kit : Oring Set, Diaphragm Kit, Plunger Assembly, Fastener, Springs, Manual Override, Guide assembly	99
Solenoid Kit : Solenoid, Gasket and Nut	34

APPROVAL

(★ applied for)

Approval	TYPE 4X, 6P	IP67	Ex d IIC T4 or T5 or T6 IP66	Ex ia IIC T6 IP67	DGMS	CCOE
		✓	✓	✓	✓	✓
CE		✓	✓	✓		
UL	✓		*			
			✓	✓		
EAC			✓	✓		
			✓	✓		



2/2 DIAPHRAGM OPERATED, NORMALLY CLOSED/ OPEN SOLENOID VALVE

SPECIFICATION

SIZE	PORT CONNECTION		PRE-SSURE bar		ORIFICE (mm)	FLOW FACTOR kv (LPM OF WATER @ 1 bar ΔP)	VALVE TYPE	PILOT PRESSURE	BODY MATERIAL AND INTERNALS						SEALS ①						MANUAL OVERRIDE			SOLENOID ENCLOSURE						SUFFIX		POWER VA			CONSTRUCTION REFERENCE NUMBER
	BSP(F)	NPT(F)	MINIMUM	MAXIMUM					ALUMINIUM ②	CF8M & SS316	CF8 & SS316	NBR	Viton	EPDM	HYREL	PTFE	NIL	STAYPUT CUM MOMENTARY	MOMENTARY	FLYING LEAD	PLUG IN, IP67	SQ. PLUG IN, IP67	TERMINAL BOX IP67	EXPLOSION PROOF IIC, IP67	LARGE ENCLOSURE	SOLENOID SIZE	OXYGEN	AMONIA	AC INRUSH	AC HOLDING	DC				

2/2 NORMALLY CLOSED

1/2"	4G	4R	0.5	10	12	60	24101			* B12	B13	S0	S2	S1		* M6	M8	22	25	T	E	III	14	✓	✓	18	12	8	29
			1	20	12	60	24102			* B12	B13	S0	S2	S1		* M6	M8	22	25	T	E	III	14	✓	✓	18	12	8	29
3/4"	6G	6R	0.5	10	20	110	24101			* B12	B13	S0	S2	S1		* M6	M8	22	25	T	E	III	14	✓	✓	18	12	8	30
			1	20	20	110	24102			* B12	B13	S0	S2	S1		* M6	M8	22	25	T	E	III	14	✓	✓	18	12	8	30
1"	8G	8R	0.5	10	25	185	24109			* B12	B13	S0	S2			* M6	M8	22	25	T	E	III	14	✓	✓	18	12	8	33
			1	20	25	185	24102V01			* B12	B13	S0	S2			* M6	M8	22	25	T	E	III	14	✓	✓	18	12	8	33
1 1/4"	10G	10R	0.5	10	40	400	24101			B12	B13	S0	S2			* M6	M8	22	25	T	E	III	14	✓	✓	18	12	8	34
			1	20	40	400	24102			B12	B13	S0	S2			* M6	M8	22	25	T	E	III	14	✓	✓	18	12	8	34
1 1/2"	12G	12R	0.5	10	40	440	24101			B12	B13	S0	S2			* M6	M8	22	25	T	E	III	14	✓	✓	18	12	8	35
			1	20	40	440	24102			B12	B13	S0	S2			* M6	M8	22	25	T	E	III	14	✓	✓	18	12	8	35
2"	16G	16R	0.5	10	50	650	24101V01			B12	B13	S0	S2			* M6	M8	22	25	T	E	III	14	✓	✓	18	12	8	36
			1	20	50	650	24102V01			B12	B13	S0	S2			* M6	M8	22	25	T	E	III	14	✓	✓	18	12	8	36
2 1/2"	20G	20R	0.5	10	65	800	24101			B12	B13	S0	S2			* M6	M8	22	25	T	E	III	14	✓	✓	18	12	8	85
			1	20	65	800	24102			B12	B13	S0	S2			* M6	M8	22	25	T	E	III	14	✓	✓	18	12	8	85
3"	24G		0.5	10	80	1000	24101			B12	B13	S0	S2			* M6	M8	22	25	T	E	III	14	✓	✓	18	12	8	85
			1	20	80	1000	24102			B12	B13	S0	S2			* M6	M8	22	25	T	E	III	14	✓	✓	18	12	8	85

2/2 NORMALLY OPEN

1/2"	4G	4R	0.5	10	12	60	24201			* B12	B13	S0	S2	S1		* M6	M8	22	25	T	E	III	14	✓	✓	18	12	8	37
			1	20	12	60	24202			* B12	B13	S0	S2	S1		* M6	M8	22	25	T	E	III	14	✓	✓	18	12	8	37
3/4"	6G	6R	0.5	10	20	110	24201			* B12	B13	S0	S2	S1		* M6	M8	22	25	T	E	III	14	✓	✓	18	12	8	38
			1	20	20	110	24202			* B12	B13	S0	S2	S1		* M6	M8	22	25	T	E	III	14	✓	✓	18	12	8	38
1"	8G	8R	0.5	10	25	185	24201V01			* B12	B13	S0	S2			* M6	M8	22	25	T	E	III	14	✓	✓	18	12	8	39
			1	20	25	185	24202V01			* B12	B13	S0	S2			* M6	M8	22	25	T	E	III	14	✓	✓	18	12	8	39
1 1/4"	10G	10R	0.5	10	40	400	24201			B12	B13	S0	S2			* M6	M8	22	25	T	E	III	14	✓	✓	18	12	8	42
			1	20	40	400	24202			B12	B13	S0	S2			* M6	M8	22	25	T	E	III	14	✓	✓	18	12	8	42
1 1/2"	12G	12R	0.5	10	40	440	24201			B12	B13	S0	S2			* M6	M8	22	25	T	E	III	14	✓	✓	18	12	8	43
			1	20	40	440	24202			B12	B13	S0	S2			* M6	M8	22	25	T	E	III	14	✓	✓	18	12	8	43
2"	16G	16R	0.5	10	50	650	24201V01			B12	B13	S0	S2			* M6	M8	22	25	T	E	III	14	✓	✓	18	12	8	40
			1	20	50	650	24202V01			B12	B13	S0	S2			* M6	M8	22	25	T	E	III	14	✓	✓	18	12	8	40
2 1/2"	20G	20R	0.5	10	65	800	24201			B12	B13	S0	S2			* M6	M8	22	25	T	E	III	14	✓	✓	18	12	8	85
			1	20	65	800	24202			B12	B13	S0	S2			* M6	M8	22	25	T	E	III	14	✓	✓	18	12	8	85
3"	24G		0.5	10	80	1000	24201			B12	B13	S0	S2			* M6	M8	22	25	T	E	III	14	✓	✓	18	12	8	85
			1	20	80	1000	24202			B12	B13	S0	S2			* M6	M8	22	25	T	E	III	14	✓	✓	18	12	8	85

Cable Entry	T	E				
		Ex d	Ex ia	Ex emb		
M20 x 1.5	19	39	87MS	66MS	58MS	58LTMS
M25 x 1.5			87	66	58	58LT
1/2" NPT	16	37	87NS	66NS	58NS	58LTNS

* = Do not specify when opted for. Refer Page # 22 for Value of *
✓ = Options available

① Select appropriate Rubber Diaphragm for Media other than AIR.

② Aluminium Cast Body to be Only used with AIR Media.



Engineering For The Future

2/2 DIAPHRAGM OPERATED, FLANGE END, NORMALLY CLOSED/ OPEN SOLENOID VALVE

SPECIFICATION

PORT CONNECTION			PRE-SSURE bar		ORIFICE (mm)	FLOW FACTOR KV (LPM OF WATER @ 1 bar ΔP)	VALVE TYPE	BODY MATERIAL AND INTERNALS			SEALS ①				MANUAL OVERRIDE		SOLENOID ENCLOSURE				SUFFIX		POWER VA		CONSTRUCTION REFERENCE NUMBER
SIZE	FLANGE	CONNECTION	MINIMUM	MAXIMUM				ALUMINIUM	SS 316/ CF8	SS 316/ CF8M	NBR	Viton	EPDM	HYTREL	PTFE	NIL	STAYPUT CUM MOMENTARY	WEATHER PROOF	EXPLOSION PROOF	OXYGEN	AMONIA	AC INRUSH	AC HOLDING	DC	

ASME B16.5 150 CLASS FLANGE

2/2 NORMALLY CLOSED

1/2" 4F	0.5	20	12	60	FADFG00	B13	B12	S0	S2	S1			✳	M6	M8	22	25	T	E	III	14	✓	✓	18	12	8
3/4" 6F	0.5	20	20	110	FADFGA0	B13	B12	S0	S2	S1			✳	M6	M8	22	25	T	E	III	14	✓	✓	18	12	8
1" 8F	0.5	20	25	185	FADFGA1V01	B13	B12	S0	S2				✳	M6	M8	22	25	T	E	III	14	✓	✓	18	12	8
1 1/4" 10F	0.5	20	40	400	FADFGA3	B13	B12	S0	S2				✳	M6	M8	22	25	T	E	III	14	✓	✓	18	12	8
1 1/2" 12F	0.5	20	40	440	FADFGA4	B13	B12	S0	S2				✳	M6	M8	22	25	T	E	III	14	✓	✓	18	12	8
2" 16F	0.5	20	50	650	FADFGA5V01	B13	B12	S0	S2				✳	M6	M8	22	25	T	E	III	14	✓	✓	18	12	8
2 1/2" 20F	0.5	20	65	800	FADFGA6	B13	B12	S0	S2				✳	M6	M8	22	25	T	E	III	14	✓	✓	18	12	8
3" 24F	0.5	20	80	1000	FADFGA7	B13	B12	S0	S2				✳	M6	M8	22	25	T	E	III	14	✓	✓	18	12	8
4" 32F	1	20	100	1400	FADFGA8	B13	B12	S0	S2				✳	M6	M8	22	25	T	E	III	14	✓	✓	18	12	8

ASME B16.5 300 CLASS FLANGE

1/2" 4F	0.5	20	12	60	FADFH00	B13	B12	S0	S2	S1			✳	M6	M8	22	25	T	E	III	14	✓	✓	18	12	8
3/4" 6F	0.5	20	20	110	FADFHA0	B13	B12	S0	S2	S1			✳	M6	M8	22	25	T	E	III	14	✓	✓	18	12	8
1" 8F	0.5	20	25	185	FADFHA1V01	B13	B12	S0	S2				✳	M6	M8	22	25	T	E	III	14	✓		18	12	8
1 1/4" 10F	0.5	20	40	400	FADFHA3	B13	B12	S0	S2				✳	M6	M8	22	25	T	E	III	14	✓	✓	18	12	8
1 1/2" 12F	0.5	20	40	440	FADFHA4	B13	B12	S0	S2				✳	M6	M8	22	25	T	E	III	14	✓	✓	18	12	8
2" 16F	0.5	20	50	650	FADFHA5V01	B13	B12	S0	S2				✳	M6	M8	22	25	T	E	III	14	✓	✓	18	12	8
2 1/2" 20F	0.5	20	65	800	FADFHA6	B13	B12	S0	S2				✳	M6	M8	22	25	T	E	III	14	✓	✓	18	12	8
3" 24F	0.5	20	80	1000	FADFHA7	B13	B12	S0	S2				✳	M6	M8	22	25	T	E	III	14	✓	✓	18	12	8

ASME B16.5 150 CLASS FLANGE

2/2 NORMALLY OPEN

1/2" 4F	0.5	20	12	60	FAEFG00	B13	B12	S0	S2	S1			✳	M6	M8	22	25	T	E	III	14	✓	✓	18	12	8
3/4" 6F	0.5	20	20	110	FAEFGA0	B13	B12	S0	S2	S1			✳	M6	M8	22	25	T	E	III	14	✓	✓	18	12	8
1" 8F	0.5	20	25	185	FAEFGA1V01	B13	B12	S0	S2				✳	M6	M8	22	25	T	E	III	14	✓	✓	18	12	8
1 1/4" 10F	0.5	20	40	400	FAEFGA3	B13	B12	S0	S2				✳	M6	M8	22	25	T	E	III	14	✓	✓	18	12	8
1 1/2" 12F	0.5	20	40	440	FAEFGA4	B13	B12	S0	S2				✳	M6	M8	22	25	T	E	III	14	✓	✓	18	12	8
2" 16F	0.5	20	50	650	FAEFGA5V01	B13	B12	S0	S2				✳	M6	M8	22	25	T	E	III	14	✓	✓	18	12	8
2 1/2" 20F	0.5	20	65	800	FAEFGA6	B13	B12	S0	S2				✳	M6	M8	22	25	T	E	III	14	✓	✓	18	12	8
3" 24F	0.5	20	80	1000	FAEFGA7	B13	B12	S0	S2				✳	M6	M8	22	25	T	E	III	14	✓	✓	18	12	8

ASME B16.5 300 CLASS FLANGE

1/2" 4F	0.5	20	12	60	FAEFH00	B13	B12	S0	S2	S1			✳	M6	M8	22	25	T	E	III	14	✓	✓	18	12	8
3/4" 6F	0.5	20	20	110	FAEFHA0	B13	B12	S0	S2	S1			✳	M6	M8	22	25	T	E	III	14	✓	✓	18	12	8
1" 8F	0.5	20	25	185	FAEFHA1V01	B13	B12	S0	S2				✳	M6	M8	22	25	T	E	III	14	✓		18	12	8
1 1/4" 10F	0.5	20	40	400	FAEFHA3	B13	B12	S0	S2				✳	M6	M8	22	25	T	E	III	14	✓	✓	18	12	8
1 1/2" 12F	0.5	20	40	440	FAEFHA4	B13	B12	S0	S2				✳	M6	M8	22	25	T	E	III	14	✓	✓	18	12	8
2" 16F	0.5	20	50	650	FAEFHA5V01	B13	B12	S0	S2				✳	M6	M8	22	25	T	E	III	14	✓	✓	18	12	8
2 1/2" 20F	0.5	20	65	800	FAEFHA6	B13	B12	S0	S2				✳	M6	M8	22	25	T	E	III	14	✓	✓	18	12	8
3" 24F	0.5	20	80	1000	FAEFHA7	B13	B12	S0	S2				✳	M6	M8	22	25	T	E	III	14	✓	✓	18	12	8

CODE	FLANGE TYPE
F	Flange End
AD	24102 SOV as base Model
AE	24202 SOV as base Model
FG	Flange End as per ASME 16.5 #150 Class
FH	Flange End as per ASME 16.5 #300 Class

Cable Entry	SOLENOID				
	T	E			
		Ex d	Ex ia	Ex emb	
M20 x 1.5	19	39	87MS	66MS	58MS 58LTMS
M25 x 1.5			87	66	58 58LT
1/2" NPT	16	37	87NS	66NS	58NS 58LTNS

✳ = Do not specify when opted for. Refer Page # 22 for Value of
✓ = Options available

① Select appropriate Rubber Diaphragm for Media other than AIR.

2/2 DIAPHRAGM OPERATED, NORMALLY CLOSED/ OPEN SOLENOID VALVE

ORDERING CODE

VALVE+SOLENOID

VALVE TYPE - SUFFIX - PORT CONNECTION - BODY AND INTERNALS - MANUAL OVERRIDE
 - SEAL - MEDIA + SIZE - VOLTAGE - CURRENT - POWER - SOLENOID ENCLOSURE -
 SPECIAL VERSION - POWER - INSULATION - APPROVAL
 e.g. 24101-12-4G-S0+I-230V-50Hz-22, 24102V01-25-B12-M6-S2+III-24V-DC-16-H

DIMENSIONS

All Dimensions are in mm

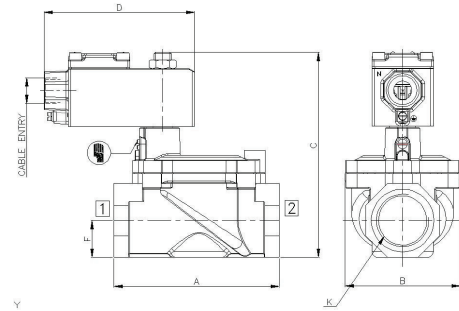
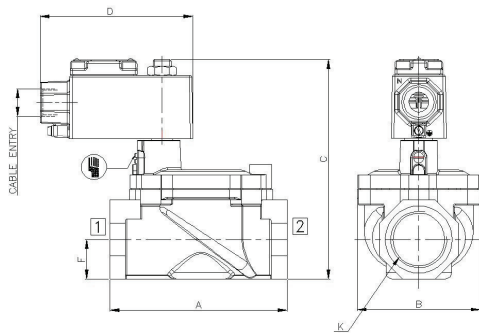
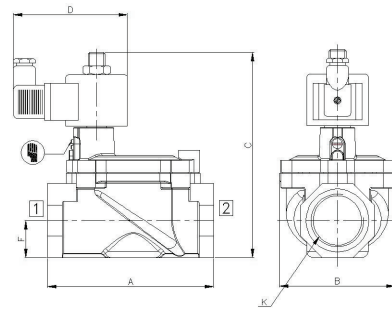
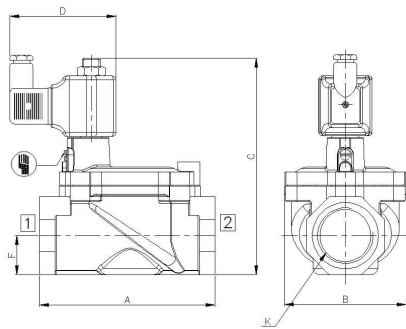

NW	K (PORT SIZE)	A	B	C	D	E	F	CONST. REF.
VALVE TYPE: 24109, 24101, 24102								
12	1/2"	65	50	128	60	76	15	29
20	3/4"	84	64	137	60	85	17	30
25	1"	110	82	148	60	76	22	33
40	1 1/4"	135	94	166	60	95	30	34
40	1 1/2"	135	94	166	60	95	30	35
50	2"	165	140	184	60	128	38	36
65	2 1/2"	200	169	208	60	159	45	54
80	3"	235	198	224	60	194	53	56

6



2/2 DIAPHRAGM OPERATED, NORMALLY CLOSED/ OPEN SOLENOID VALVE

DIMENSIONS

All Dimensions are in mm

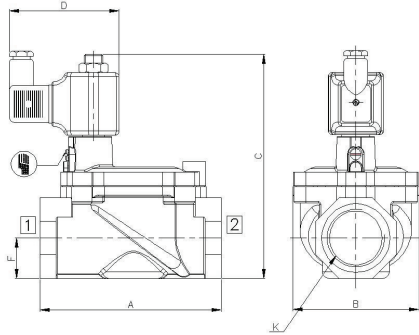

PLUG IN SOLENOID TYPE 22

NW	K (PORT SIZE)	A	B	C	D	E	F	CONST. REF.	
VALVE TYPE:		24109, 24101,24102							
25	1"	110	82	148	60	76	22	33	
40	1 1/4"	135	94	166	60	95	30	34	
40	1 1/2"	135	94	166	60	95	30	35	
50	2"	165	140	184	60	128	38	36	
65	2 1/2"	200	169	208	60	159	45	54	
80	3"	235	198	224	60	194	53	56	

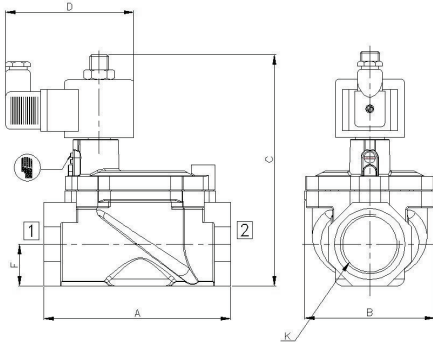

SQUARE PLUG IN SOLENOID TYPE 25

NW	K (PORT SIZE)	A	B	C	D	E	F	CONST. REF.	
VALVE TYPE:		24109, 24101,24102							
25	1"	110	82	148	68	76	22	33	
40	1 1/4"	135	94	166	68	95	30	34	
40	1 1/2"	135	94	166	68	95	30	35	
50	2"	165	140	184	68	128	38	36	
65	2 1/2"	200	169	208	68	159	45	54	
80	3"	235	198	224	68	194	53	56	

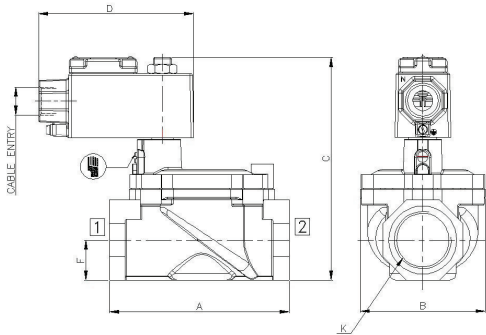

TERMINAL BOX/ Ex d ENCLOSURE, TYPE 16, 19, 37, 39, 58, 58LT

NW	K (PORT SIZE)	A	B	C	D	E	F	CONST. REF.	
VALVE TYPE:		24109, 24101,24102							
25	1"	110	82	148	85	76	22	33	
40	1 1/4"	135	94	166	85	95	30	34	
40	1 1/2"	135	94	166	85	95	30	35	
50	2"	165	140	184	85	128	38	36	
65	2 1/2"	200	169	208	85	159	45	54	
80	3"	235	198	224	85	194	53	56	

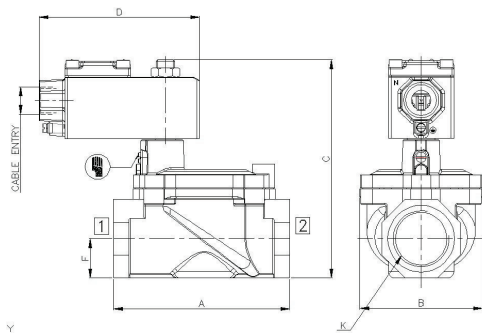

TERMINAL BOX/ Ex d LARGE ENCLOSURE, TYPE 16, 19, 37, 39, 58, 58LT, LC

NW	K (PORT SIZE)	A	B	C	D	E	F	CONST. REF.	
VALVE TYPE:		24109, 24101,24102							
25	1"	110	82	148	97	76	22	33	
40	1 1/4"	135	94	166	97	95	30	34	
40	1 1/2"	135	94	166	97	95	30	35	
50	2"	165	140	184	97	128	38	36	
65	2 1/2"	200	169	208	97	159	45	54	
80	3"	235	198	224	97	194	53	56	

2/2 DIAPHRAGM OPERATED, NORMALLY CLOSED/ OPEN SOLENOID VALVE

DIMENSIONS

All Dimensions are in mm

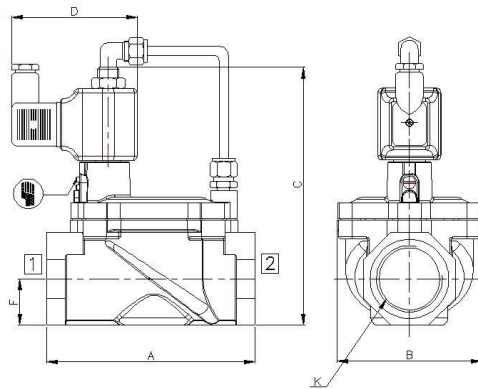

PLUG IN SOLENOID TYPE 22

NW	K (PORT SIZE)	A	B	C	D	E	F	G	CONST. REF.
VALVE TYPE: 24201,24202									
12	1/2", 3/8", 1/4"	65	50	128	82	00	15	00	37
20	3/4"	84	64	137	82	00	17	00	38
25	1"	110	82	148	82	00	25	00	39
40	1 1/2"	135	94	166	82	00	30	00	40
50	2"	165	140	184	82	00	38	00	41
65	2 1/2"	200	169	208	82	00	45	00	42
80	3"	235	198	224	82	00	53	00	43

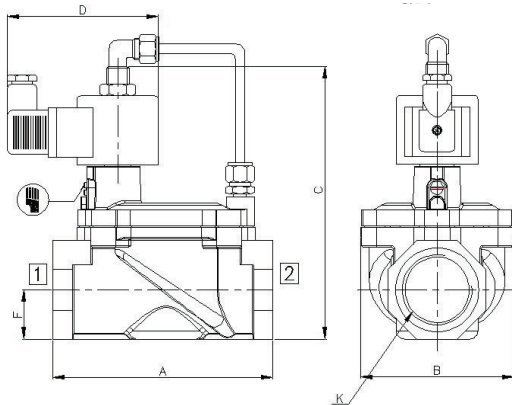

SQUARE PLUG IN SOLENOID TYPE 25

NW	K (PORT SIZE)	A	B	C	D	E	F	G	CONST. REF.
VALVE TYPE: 24201, 24202									
12	1/2", 3/8", 1/4"	65	50	128	93	00	15	00	37
20	3/4"	84	64	137	93	00	17	00	38
25	1"	110	82	148	93	00	25	00	39
40	1 1/2"	135	94	166	93	00	30	00	40
50	2"	165	140	184	93	00	38	00	41
65	2 1/2"	200	169	208	93	00	45	00	42
80	3"	235	198	224	93	00	53	00	43

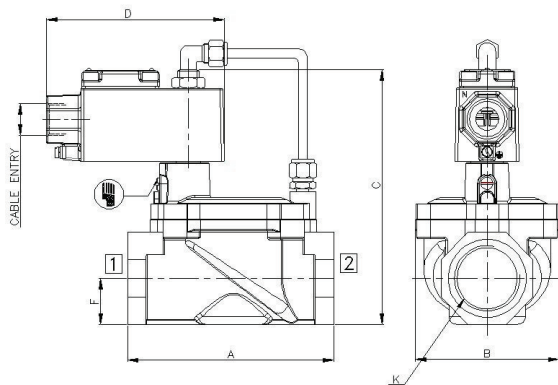

TERMINAL BOX/ Ex d ENCLOSURE, TYPE 16, 19, 37, 39, 58, 58LT

NW	K (PORT SIZE)	A	B	C	D	E	F	G	CONST. REF.
VALVE TYPE: 24201, 24202									
12	1/2", 3/8", 1/4"	65	50	128	116	00	15	00	37
20	3/4"	84	64	137	116	00	17	00	38
25	1"	110	82	148	116	00	25	00	39
40	1 1/2"	135	94	166	116	00	30	00	40
50	2"	165	140	184	116	00	38	00	41
65	2 1/2"	200	169	208	116	00	45	00	42
80	3"	235	198	224	116	00	53	00	43

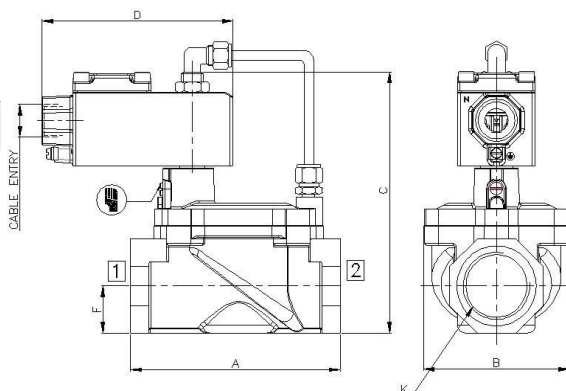

TERMINAL BOX/ Ex d LARGE ENCLOSURE, TYPE 16, 19, 37, 39, 58, 58LT, LC

NW	K (PORT SIZE)	A	B	C	D	E	F	G	CONST. REF.
VALVE TYPE: 24201, 24202									
12	1/2", 3/8", 1/4"	65	50	128	123	00	15	00	37
20	3/4"	84	64	137	123	00	17	00	38
25	1"	110	82	148	123	00	25	00	39
40	1 1/2"	135	94	166	123	00	30	00	40
50	2"	165	140	184	123	00	38	00	41
65	2 1/2"	200	169	208	123	00	45	00	42
80	3"	235	198	224	123	00	53	00	43

2/2 DIAPHRAGM OPERATED, NORMALLY CLOSED/ OPEN SOLENOID VALVE

DIMENSIONS

All Dimensions are in mm

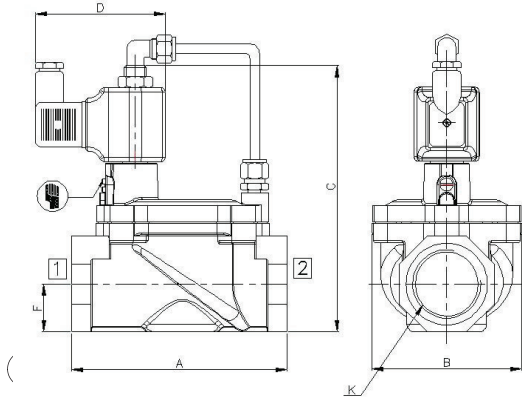

PLUG IN SOLENOID TYPE 22

NW	K (PORT SIZE)	A	B	C	D	E	F	CONST. REF.
		VALVE TYPE: 24201, 24202						
25	1"	110	82	148	82	00	22	41
40	1 1/4"	135	94	166	82	00	30	42
40	1 1/2"	135	94	166	82	00	30	43
50	2"	185	140	184	82	000	38	44
65	2 1/2"	200	169	208	82	000	45	83
80	3"	235	198	224	82	000	53	89

6

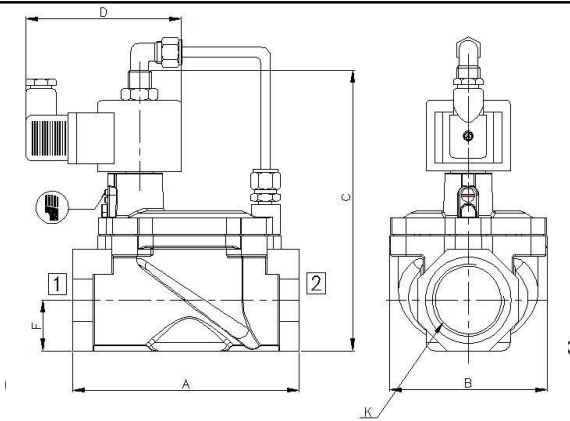

SQUARE PLUG IN SOLENOID TYPE 25

NW	K (PORT SIZE)	A	B	C	D	E	F	CONST. REF.
		VALVE TYPE: 24201, 24202						
25	1"	110	82	148	93	00	22	41
40	1 1/4"	135	94	166	93	00	30	42
40	1 1/2"	135	94	166	93	00	30	43
50	2"	185	140	184	93	000	38	44
65	2 1/2"	200	169	208	93	000	45	83
80	3"	235	198	224	93	000	53	89

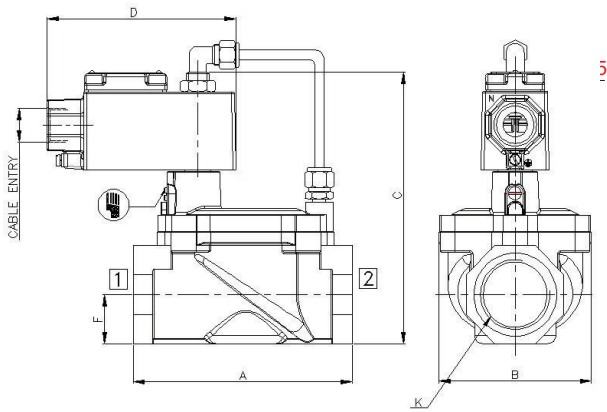

TERMINAL BOX/ Ex d ENCLOSURE, TYPE 16, 19, 37, 39, 58, 58LT

NW	K (PORT SIZE)	A	B	C	D	E	F	CONST. REF.
		VALVE TYPE: 24201, 24202						
25	1"	110	82	148	116	00	22	41
40	1 1/4"	135	94	166	116	00	30	42
40	1 1/2"	135	94	166	116	00	30	43
50	2"	185	140	184	116	000	38	44
65	2 1/2"	200	169	208	116	00	45	83
80	3"	235	198	224	116	000	53	89

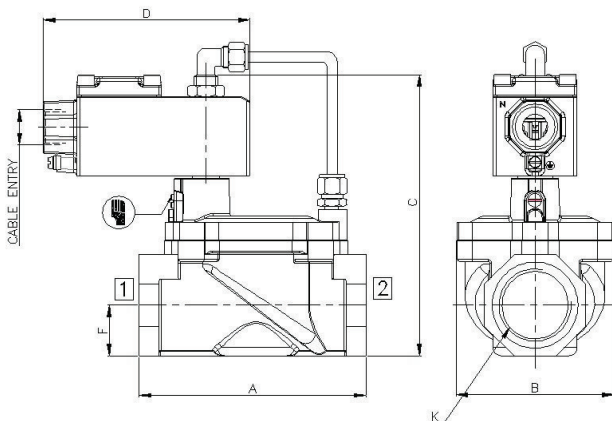

TERMINAL BOX/ Ex d LARGE ENCLOSURE, TYPE 16, 19, 37, 39, 58, 58LT, LC

NW	K (PORT SIZE)	A	B	C	D	E	F	CONST. REF.
		VALVE TYPE: 24201, 24202						
25	1"	110	82	148	123	00	22	41
40	1 1/4"	135	94	166	123	00	30	42
40	1 1/2"	135	94	166	123	00	30	43
50	2"	185	140	184	123	000	38	44
65	2 1/2"	200	169	208	116	000	45	83
80	3"	235	198	224	116	000	53	89

2/2 DIAPHRAGM OPERATED, NORMALLY CLOSED SOLENOID VALVE

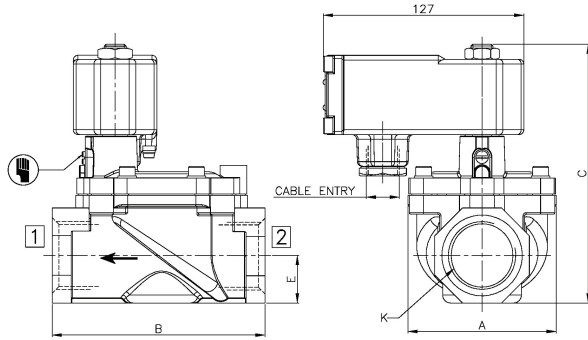

BCE SOLENOID/ Ex d TYPE 87

NW	K (PORT SIZE)	A	B	C	E	CONST. REF.
VALVE TYPE: 24101, 24102						
12	1/2", 3/8", 1/4"	50	65	128	15	29
20	3/4"	64	84	137	17	30
25	1"	82	110	148	22	33
40	1 1/2"	94	135	166	30	35
50	2"	140	165	184	38	36
65	2 1/2"	169	200	208	45	85
80	3"	198	235	224	53	85

6

2/2 DIAPHRAGM OPERATED, NORMALLY OPEN SOLENOID VALVE

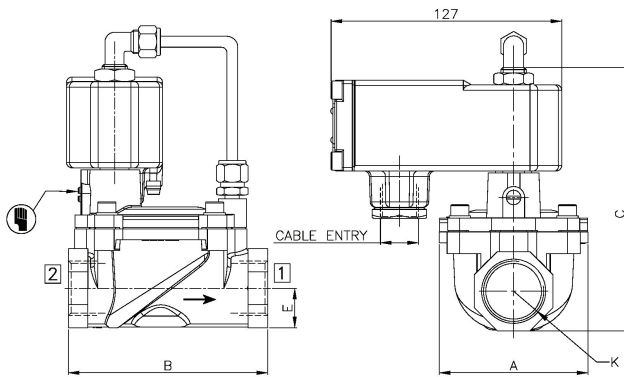

BCE SOLENOID/ Ex d TYPE 87

NW	K (PORT SIZE)	A	B	C	E	CONST. REF.
VALVE TYPE: 24201, 24202						
12	1/2", 3/8", 1/4"	50	65	128	15	37
20	3/4"	64	84	137	17	38
25	1"	82	110	148	22	39
40	1 1/2"	94	135	166	30	43
50	2"	140	165	184	38	40
65	2 1/2"	169	200	208	45	85
80	3"	198	235	224	53	85